

TERAFLEX

INSTALLATION GUIDE

Installation Guide for the Low Range Dana 20 Kit (LOW20) Part #002112020

TeraFlex, Inc.
5680 W Dannon Way
West Jordan, UT 84081
Phone/801.288.2585
Fax/801.713.2313
www.teraflex.com



Attention: Verify that this is the appropriate kit for your application prior to beginning work.

The Low20 uses a six spline input gear designed for use with factory manual transmissions. The Low20-Auto kit was designed to be used on vehicles using the Dana 20 transfer case and the factory automatic transmission. The input gear of this kit has fifteen splines. Care should be taken to verify proper spline count and application for this kit prior to beginning installation.

The Model 20 Transfer Case is a four-position type that provides two gear ratios in 4-wheel drive, one ratio in 2-wheel drive, and a neutral position. The TeraLow Low20 gear set, in 4-wheel drive low, provides a reduction ratio of 3.15:1 (a stock Jeep Model 20 has a ratio of 2.03:1) for off-road use and applications that require increased pulling power. Four-wheel drive high and 2-wheel drive high both provide 1:1 ratio in the transfer case. Neutral position is used for stationary power takeoff applications such as winching. In neutral, power is not transmitted to the wheels.

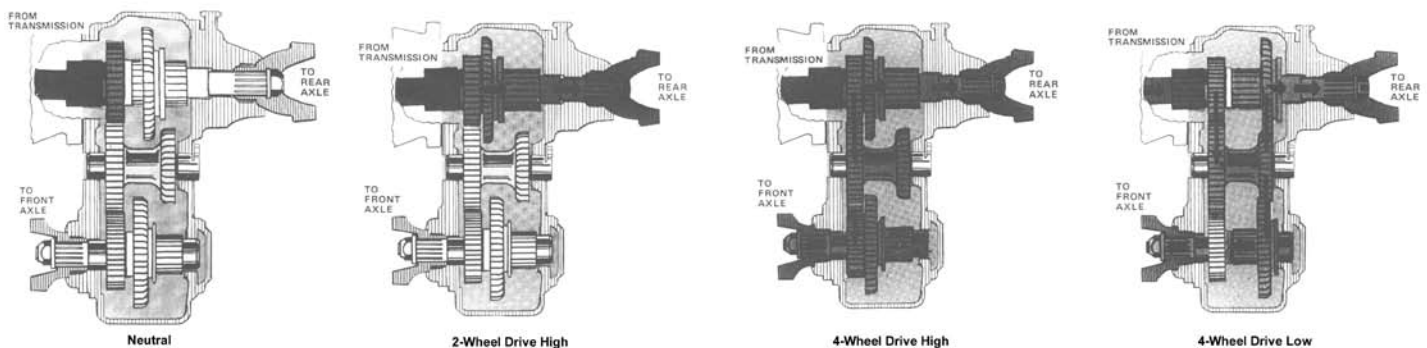

Power flow through the transfer case in the four positions is shown in the figures above. The darkened areas of the illustrations show which gears are engaged and the positions of the gears in various drive ranges.

Removal

- (1) Remove shift lever knob, boot, and shift lever.
- (2) Raise and support vehicle and drain lubricant.
- (3) Mark propeller shafts for reference at assembly and disconnect front and rear propeller shafts from output shaft yokes.
- (4) Disconnect parking brake cable at equalizer.
- (5) Disconnect speedometer cable at transfer case.
- (6) Remove transfer-case-to-transmission attaching bolts and install one 3/8-16 x 4 inch dowel pin or cut a piece of all thread in 4-inch lengths to use in place of dowels on each side of case to use as guide for installation.

- (7) Remove transfer case.
- (8) Remove transmission-to-transfer case gasket.

Disassembly

NOTE: Refer to exploded view for part identification.

- (1) Remove bottom cover and gaskets.
- (2) Remove bolts attaching rear bearing cap assembly to transfer case and remove assembly.
- (3) Remove the main shaft gear through front of case.
- (4) Remove intermediate shaft lock plate.
- (5) Using brass drift and a plastic mallet, drive intermediate shaft out of rear of case.
- (6) Remove intermediate gear assembly through bottom of case.

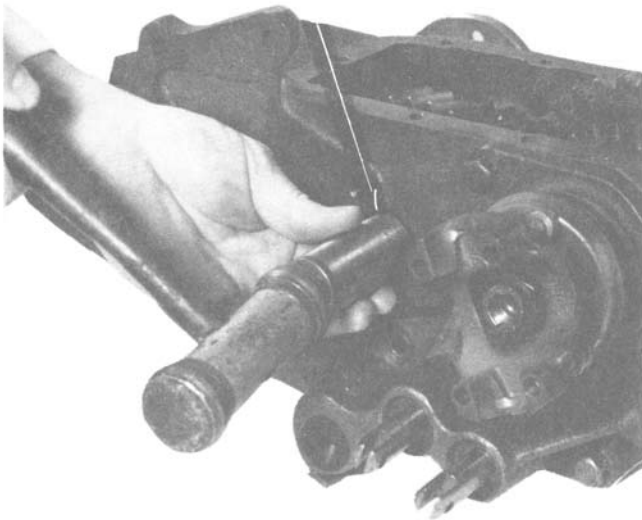

- (7) Remove front output shaft nut and washer.
- (8) Remove front output shaft yoke.
- (9) Remove cover plate attaching screws and remove cover.

CAUTION: When removing cover plate, take care to avoid damage to the shims between the cover and case.

- (10) Position both shift rods in neutral.
- (11) Remove rear output shaft shift fork setscrew.
- (12) Remove poppet ball and spring plugs.
- (13) Insert punch through pin hole in rod and rotate rear shift rod 1/4-turn counterclockwise and pull rod out of case.

NOTE: When shift fork is free of rod, use hand to catch poppet ball and spring under shift rod.

- (14) Remove front shift rod housing attaching screws and slide housing from remaining shift rail.

NOTE: When housing is free of the rod, use hand to catch poppet ball and spring under shift rail.

- (15) Using hammer and brass drift, drive rear output shaft towards rear of case.
- (16) Remove gears, spacer, and thrust washer from inside case and rotate shift rod to expose the setscrew.
- (17) Remove setscrew and pull out shift rod.

Grinding



Dana 20 case before grinding.



Dana 20 case after grinding.

Check clearance by attaching rear output shaft assembly to back of case.

Slide gear through positions with shaft and sliding output gear in place to make sure case clearance is complete.

Note: Most Dana 20s require grinding. There are some that will not require it, be sure to check this **Before** putting the case all the way back together.

Cleaning and inspection

Wash all transfer case components and transfer case housing in solvent. Clean gasket material from all gasket surfaces and dry all components with compressed air.

Inspect all bearings, thrust washers, shafts and gears for excessive wear, pitting, and scoring. If any part is damaged or worn, it must be replaced.

Assembly

- (1) Slide front output shaft shift rod partially into case.
- (2) Place front output shaft shift fork on rod with bolt hole aligned with countersunk hole in rod.
- (3) Install setscrew and tighten to 14 foot-pounds torque.
- (4) Place rear output shaft shift fork in proper position in case.
- (5) Set new rear output shaft sliding gear on shift fork with slot in gear facing rear of case.
- (6) Install rear cone and roller on front output shaft.

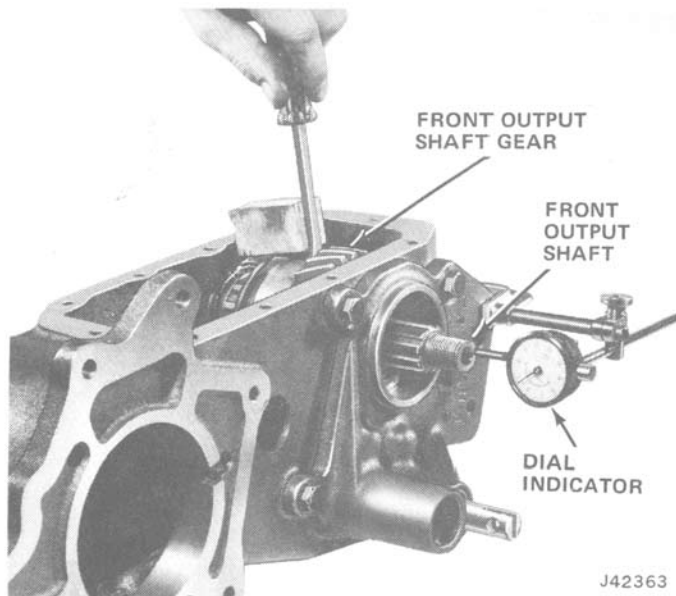

- (7) Insert front output shaft gears, thrust washers, and bearing in place and slide output shaft through both gears.
- (8) Install front cone and roller on front output shaft.
- (9) Install front and rear front output shaft bearing cups.
- (10) Install rear bearing shims and cover plate, and tighten cover plate attaching bolts to 30 foot-pounds.
- (11) Using suitable bearing driver, drive front cone and roller onto front output shaft.
- (12) Place thrust washer on front output shaft.
- (13) Place front output shaft shift rod detent spring in shift rod housing.
- (14) Start housing on to the front output shaft shift rod and place poppet ball on top of spring and depress into housing with a punch and tilt transfer case to slide interlock to the right.

- (15) Slide rear output shaft shift rod into housing far enough to retain poppet ball and interlock pin.
- (16) Place large front output gear in case.
- (17) Position rear output shaft shift rod with countersunk hole up and fork engaged in front output shaft sliding gear. Rotate rod 1/4-turn counterclockwise.
- (18) Position and hold shift fork in case and push shift rod through fork.
- (19) Rotate shift rod 1/4-turn clockwise and align countersunk hole in shift rod with hole in shift fork.
- (20) Install setscrew and tighten to 14 foot-pounds torque.
- (21) Install housing attaching bolts and tighten to 28 to 30 foot-pounds torque.
- (22) Attach a dial indicator to shift rod housing to check front output shaft bearing adjustment.
- (23) Pry shaft to extreme rear position and set indicator to zero.
- (24) Pry shaft forward and read indicator. End play should be 0.001 inch to 0.003 inch which can be adjusted by changing the rear bearing cover shims.
- (25) Assemble intermediate gear rollers and spacers with heavy grease.
- (26) Place intermediate gear thrust washers in case with tangs aligned with grooves in case.

NOTE: Thrust washers fit in case with tangs aligned with grooves in case. Rear washer can be held in place by starting intermediate shaft into case. Hold front washer in position with heavy grease.

- (27) Position intermediate gear in case and, using rawhide mallet or lead hammer, drive intermediate shaft into intermediate gear.

NOTE: After intermediate gear is in place, rotate gear and check clearance to shift rail. Make sure the gear does not contact the rail. If it does you will need to mark the rail and remove it. Grind the area off the rail enough to make clearance.

- (28) Install intermediate shaft lock plate, lockwasher, and bolt. Tighten bolt to 14 foot-pounds torque.
- (29) Install rear bearing cap assembly using a new gasket, and slide rear output shaft through gears. Tighten bearing cap bolts to 30 foot-pounds torque.
- (30) Install front yoke seal.
- (31) Install front propeller shaft yoke and tighten to 100 foot-pounds torque.
- (32) Install bottom cover and gasket. Tighten bolts to 14 foot-pounds torque.

Installation

- (1) Install new input gear on transmission mainshaft.
- (2) Install new transmission-to-transfer case gasket on transmission.
- (3) Shift transfer case to 4 WD low.
- (4) Position transfer case on dowel pins.
- (5) Rotate transfer case output shaft until the main shaft gear engages the rear output shaft gear of transfer case. Slide transfer case forward until transmission and transfer case mate.

CAUTION: *Be sure the transfer case is flush against transmission. Severe damage will result if the transfer case bolts are tightened while transfer case is binding.*

- (6) Install one upper attaching bolt (snug bolt but do not tighten).
- (7) Remove guide bolts and install all remaining attaching bolts. Tighten bolts to 30 foot-pounds torque.
- (8) Connect speedometer cable and parking brake cable.
- (9) Align reference marks and install propeller shafts. Tighten U-bolt nuts to 15 foot-pounds torque.
- (10) Fill transfer case with SAE 80-90 Gear Lubricant of API, GL-4 quality to proper level and check transmission fluid level. Synthetic oil is also recommended.
- (11) Lower vehicle.
- (12) Install transfer case shift lever, boot, and knob.

Transfer Case Specifications:

Type: Four-position
Make: Spicer
Model: 20
Gear Ratio:
High: 1:1
Low: 2.03:1 (stock)
with LOW20 3.15:1
Two-Wheel Drive: 1:1

Torque Specifications

	Foot-Pounds
Torque Specifications	
Front and Rear Output Shaft Yoke Nuts	225-250
Right and Left Shift Fork Setscrews.....	12-15
Shift Rod Housing to Case Bolts	28-30
Front Output Shaft Rear Bearing Cover to Case Bolts	28-32
Intermediate Shaft Lock Plate to Case Bolts	12-15
Rear Bearing Cap Assembly to Case Bolts	28-32
Lower Cover to Case Bolts	12-15
Transfer Case to Transmission Bolts.....	28-32

Towing Instructions

Disconnect driveline or place transmission in first gear if manual, and park if automatic. Put transfer-case in neutral. Lock in front hubs.

TERAFLEX **PRODUCT INFORMATION**

MAINTENANCE INFORMATION:

It is the buyer's responsibility to have all suspension, drivetrain, steering, and other components checked for proper tightness and torque after the first 100 miles and every 3000 miles after that.

NOTICE TO INSTALLER:

The enclosed "Warning to Driver" sticker must be installed in the vehicle in driver's view. This sticker is to act as a constant safety reminder when operating the vehicle. It is your responsibility as the equipment installer to install the provided sticker and to forward the product instructions to the vehicle's owner for review. If a "Warning to Driver" sticker or product installation guide were not included in the kit, FREE replacement stickers and instructions are available by request. It is the installer's duty to ensure a safe and controllable vehicle after the modifications have been performed.

WARNING:

Neither the seller nor the manufacturer will be liable for any loss, damage, or injury directly or indirectly arising from the use of or inability to determine the use of these products. Before using, the user shall determine the suitability of the products for its intended use, and the user shall assume all responsibility and risk in connection therewith.

WARNING TO DRIVER:

This vehicle has been modified to enhance off road performance and has unique handling characteristics. Use in harsh environments can cause extreme stress on the components. Vehicle should be inspected after being off road to make sure that all the components are in working order and safe to travel on the highway. All fasteners should be checked so that they are at the correct torque specifications as the vibration and stresses from off roading may cause critical fasteners to work loose. Extra care should be taken to inspect the critical components, steering, and brake systems. During each oil change components such as arms, tie rod ends, etc should be greased and checked for excessive wear. Any worn components should be replaced. When returning to the pavement always set or restore tire air pressure to the factory recommendation and connect or engage any disabled sway bar mechanisms. Because of the higher center of gravity and larger tires, this vehicle handles and reacts differently than many passenger cars, both on and off road. You must drive it safely! Extreme care should be taken to prevent vehicle rollover or loss of control, which can result in serious injury or death. Avoid sudden sharp turns or abrupt maneuvers. Generally, braking performance and capabilities are decreased when significantly larger/heavier tires are used, especially when used in combination with transfer case low-range reduction kits. Take this into consideration while driving. Do not add, alter or fabricate any factory or aftermarket parts to increase vehicle height over the intended height of the TeraFlex product purchased. Mixing component brand is not recommended. TeraFlex Inc. will not be responsible for any altered product or any improper installation or use of our products. We will be happy to answer any questions concerning the design, function, and correct use of our products. It is ultimately the buyer's responsibility to have all bolts/nuts checked for tightness after the first 100 miles and then every 3000 miles. Wheel alignment, steering system, suspension and drive line systems must be inspected by a qualified professional mechanic at least every 3000 miles.

TERAFLEX PRODUCT WARRANTY:

Tera Manufacturing warrants TeraFlex Suspension products to the original retail purchaser to be free of defects in material and workmanship for as long as the original purchaser owns the vehicle on which products were originally installed.

Failure to complete regular maintenance (grease every 3000 miles) on TeraFlex FlexArms will void this warranty. All other conditions of the standard TeraFlex product warranty apply.

All TeraLow products are covered by TeraFlex's two (2) year warranty to be free of defects in material and workmanship for two years from date purchased.

Tera axles are covered by a 12-month warranty to be free of defects in materials and workmanship.

This warranty does not cover or include product finish, improperly installed or applied products, improperly maintained products, products or components used for racing or competition or damage due to abuse or neglect, products that fail due to the use of larger tire and wheel combinations.

All returns must be accompanied by an original invoice. It is the customer's responsibility to remove the product from the vehicle. Shipping charges are the responsibility of the customer. Tera Manufacturing will pay the return freight if the product meets the terms of warranty.

This warranty is for the replacement or repair of defective TeraFlex products only and does not include freight charges, labor charges for removal of or installation of TeraFlex or related products or components, costs incurred due to down time of the vehicle, or lost profits due to vehicle down time.

A returned goods authorization number (RGA#) must accompany any returned products. For more information please contact a TeraFlex customer service representative.

COPYRIGHT

©Copyright 2008. All rights reserved, TeraFlex Inc. Reproduction of this catalog and/or any of its contents without written permission is strictly prohibited.

TeraFlex® is a registered trademark of TeraFlex Inc. All trade names and logos including but not limited to TeraFlex, FlexArms, RockGuard, Monster, and LCG are protected by law and duplication of trade names and/or logos are strictly prohibited.

TeraFlex Inc. reserves the right to update, discontinue, redesign, modify finish, part number or component build parts if deemed necessary without written notice. TeraFlex Inc., and any associated dealers are not responsible for misprints or typographical errors that may have inadvertently been made within this instruction sheet.

Jeep® and the Jeep® grill are registered trademarks of Chrysler LLC, and have no affiliation with TeraFlex Inc.

TeraFlex, Inc. 5241 South Commerce Dr. Murray, Utah 84107
Phone/801.288.2585 Fax/801.713.2313 www.teraflex.biz